

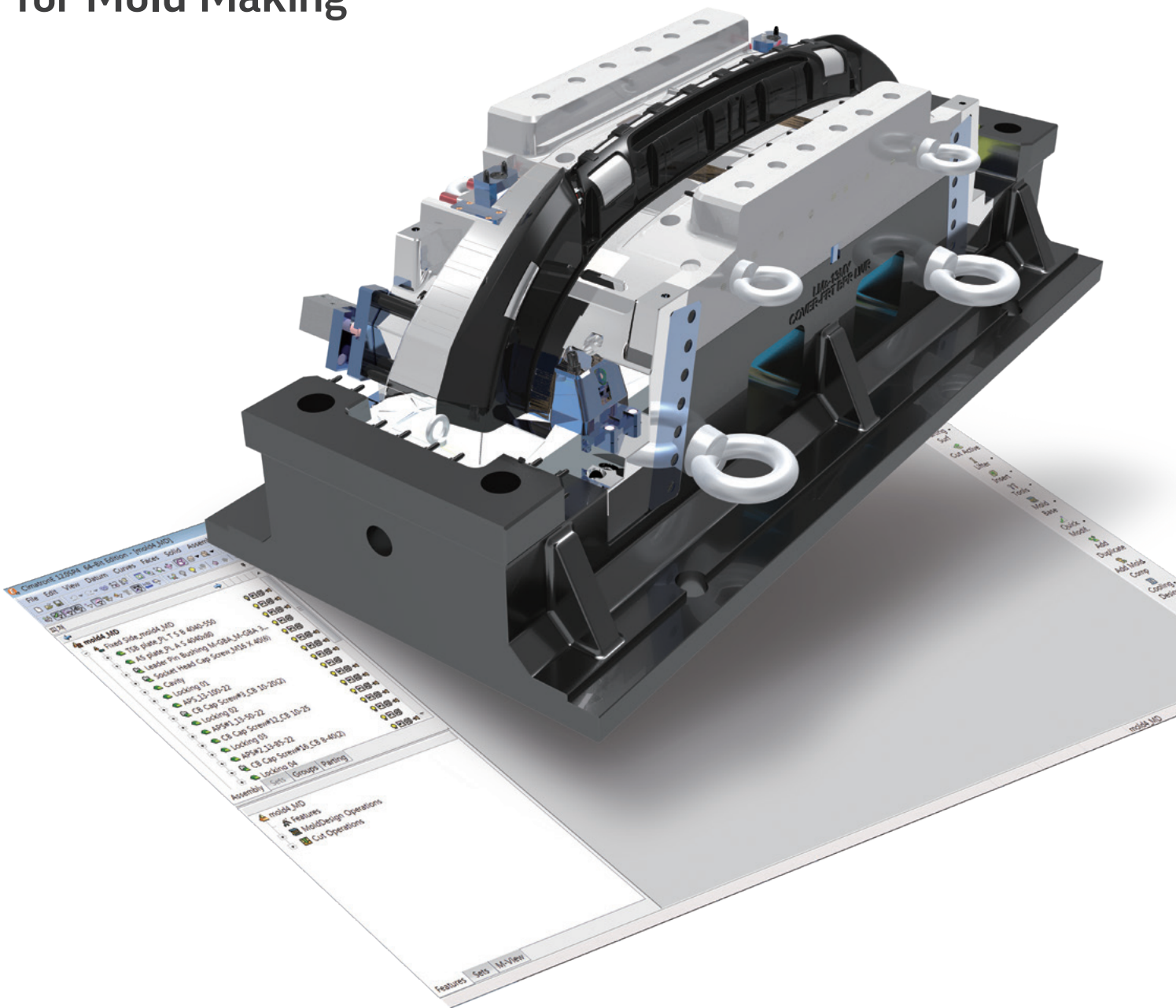

CAD/CAM Solution for Mold Making



Cimatron is a single CAD/CAM solution, dedicated to mold making. It allows you to deliver high quality molds in record time and produce molds of any complexity and size.

Data Import

- Import data from all standard formats, including mesh objects – DXF, IGES, STEP, VDA, Parasolid, SAT (ACIS), and SAB.
- Import, read and write Mesh Formats including STL, VRML, OBJ (Acrobat), PLY, 3MF, JT (read) with support for colors and textures.
- Use native formats – AutoCAD, Autodesk Inventor, CATIA, Creo, NX, SolidWorks and SolidEdge.

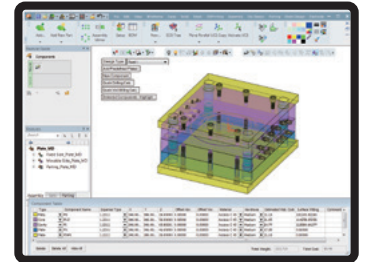

Quoting

- Use dedicated tools to extract design information.
- Extract accurate design data to Excel.

Parting and Preliminary Design

- Ensure flawless parting with analysis tools to identify undercuts, check geometry and verify parting surfaces.
- Define multiple opening directions, generate geometry for cores, cavities, sliders, lifters and other active components.
- Perform mending and surfacing work with powerful hybrid solid/surface modeling capabilities.
- Apply engineering changes at any point in the project.
- Create preliminary 3D designs to evaluate strategies and gain customer approval.

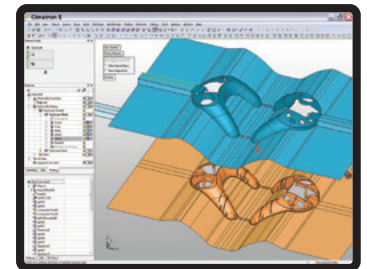

Mold Tool Design

- Load an entire mold base plate set in minutes utilizing standard and user-defined catalog parts.
- Design the core, cavity and sliders using feature-based design as well as direct modelling tools.
- Use dedicated tools to add lifters, inserts, ejectors, cooling systems, gates and runners.
- Validate your design with measurement, analysis and collision detection tools as well as FEA and ECO analysis.
- Create and reuse drawing templates incorporating customer specifications using dynamic multiple, shaded views.
- Add BOM and table of holes to your drawings taking into account machining attributes.

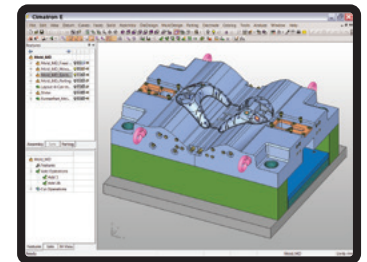

Electrode Design and Manufacturing

- Create electrodes easily and in record time using Hybrid Electrode design of surfaces and solids covering the entire design process.
- Ensure an error-free burning process, with quick definition of spark gaps, 2D or 3D orbiting, and rough offsets.
- Centrally define electrode and machine parameters and control the electrodes sent for burning.
- Create complete 2.5-5-axis machining procedures at the click of a button.
- Quickly create and edit mirrored electrodes by intelligently mirroring the electrode's geometry, without mirroring the holder and the base.

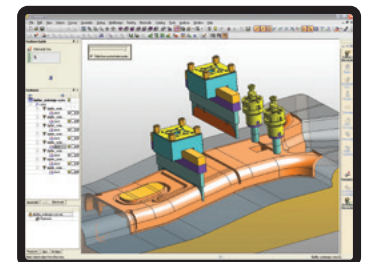

NC Programming – 2.5-5-Axis

- Use built-in CAD to add surfaces and contours, cap holes and slots, extend surfaces and apply drafts and rounds.
- Achieve efficient roughing and high quality finishing with a range of 2.5-5-axis optimized machining strategies.
- Dedicated plate machining seat generates efficient toolpaths for plate machining and drilling.
- Machine with confidence using material removal and machine simulations.
- Access a rich library of post-processors for 3- and 5-axis machines, and all leading controllers.
- Automatically generate NC Setup and Tool Table reports.
- A wide range of new, advanced NC Strategies for Pocket, Cleanup, Chamfer, Roughing, and Finishing.

